



DWP Drain Plug

Num: Eldon_0708_011

NEW PRODUCT

DWP, Drain Plug

Flexible and universal drain plug (IP44) for condensation drainage on outdoor enclosures, (Safe for any usual outdoor applications like rain, splashing water, etc).

L.S.,

When enclosures are installed in areas where there is likely to be a lot of humidity or excessive changes to the ambient temperature, it is likely that condensation will occur inside the enclosure, which could cause equipment failure.

To help prevent this from happening, a new universal drain plug has been developed (DWP02). The plug has a labyrinth design and will protect the enclosure to IP44, in any typical outdoor environment. The advantage of the DWP02 is two fold, as it not only allows any liquids or condensation to drain away, but also keeps the inside and outside pressure of the enclosure equalized, which is the major root cause for the build up of condensation.

Art no: **DWP02**



Description: Flexible and universal drain water plug to allow any liquids entering the enclosure to drain away, or to help prevent condensation occurring.

Material: TPE Elastomer (Santoprene), black

Hole diameter: 11 (+0,5) mm (0.433 inch)

Max. material thickness: 10 mm (0.393 inch)

Weight: 3g./pc

Protection rate: IP44 (NEMA 3, 3R, 13)

Pack. Quantity: 10

Item is available from stock.

For more information please visit our website: www.eldon.com



Num: Eldon_0708_011

Mounting Instructions

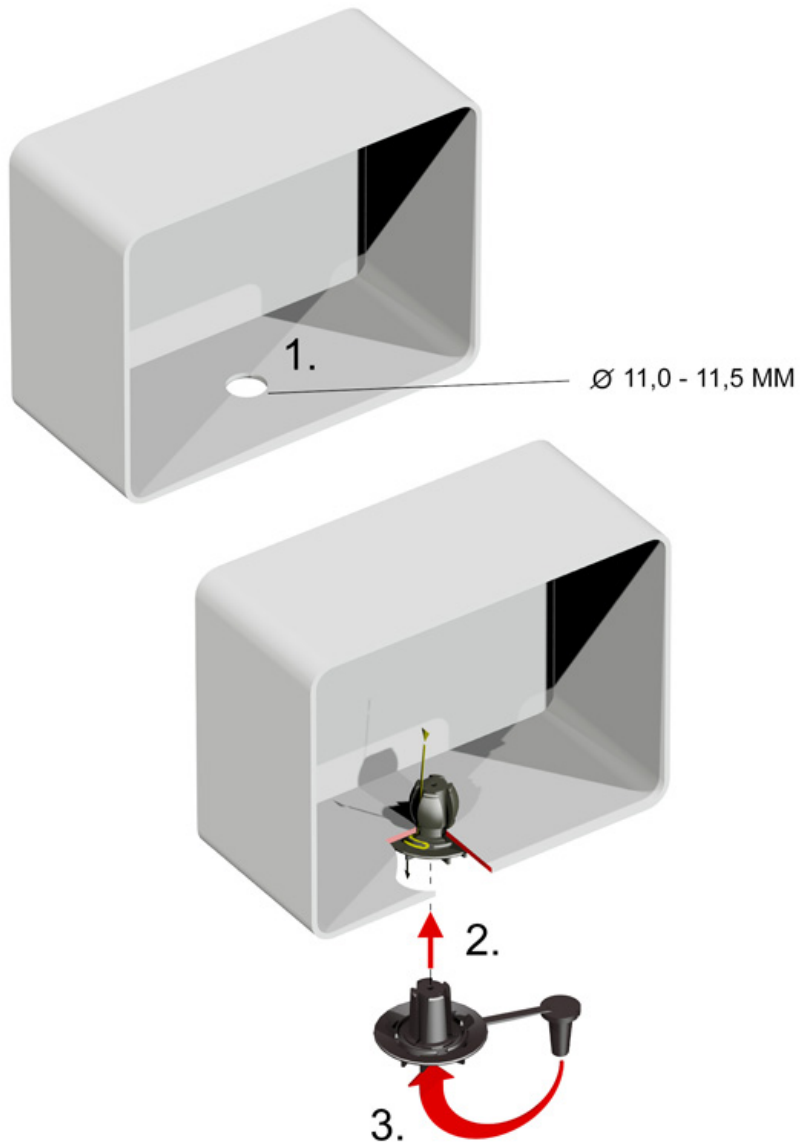

PEM307



DWP Drain Plug

Num: Eldon_0708_011

Dimensional Drawing

